



# Helix / S600



**Renewed Helix spiral door including inexpensive, fast service solution**

Traditionally, two doors are often mounted in frequently used exterior openings; an insulated door for use at night and a high speed door that is used during the day. The new Alpha Helix / S600 combines the best of both worlds in a single product.

An investment that pays for itself in next to no time!

The S600 has the identical drive system as the Helix Spiral door but has a standard track system. This door opens 6x faster as a similar sectional door but can be installed into a headroom of only 600 mm. The Helix and S600 have a standard section height of 366 mm. If you have insufficient backroom for the S600 you have the solution of the Helix with a faster speed!



U-value Helix/S600 ISO 40 mm sectional door: 5,000 x 5,000 mm: 1.77W/m<sup>2</sup>K  
U-value Helix/S600 ALU 40 mm sectional door: 5,000 x 5,000 mm: 4.25W/m<sup>2</sup>K

The best of all Worlds, the Helix and S600

### Speed

The Helix, Spiral-Door opens 6 x faster than similar sectional doors and is therefore extremely suitable in an environment where you have intensive logistic movements.

This door opens fast and depending on the door size up to 1.1M per second and real savings on the energy cost can be achieved.

### Energy-saving

The door leaf has a thickness of 40mm and a U-value of 1.77W/m<sup>2</sup>K (ISO panels / door leaf 5000mm x 5000mm). Additionally where requested we can provide high quality full width ALU vision sections.

### Space-saving

The Helix Spiral Door is a revolutionary innovation and thanks to the spiral system and chain drive does not require extended backroom. To minimize wear and tear the Spiral action of the door means the panels do not touch, roll or fold upon themselves. The Helix offers a solution in a room where the ceiling construction does not allow track hangers for a regular sectional door.

### Durability and service friendly solution in case of damage

Because of the intelligent drive-system without counterbalance, the Helix Spiral door does hardly need any service up to 200,000 cycles. The rails consist of two parts, allowing in case of damage the panels to be changed easily and quickly.

### Scopes

- Logistics
- Automotive industry
- Machine building
- Metal and electrical industry
- Chemical and pharmaceutical industry



## Technical details



Helix /S600

### Section Joint

The joint between the ISO and ALU sections is wind and watertight to (class 3 wind load).

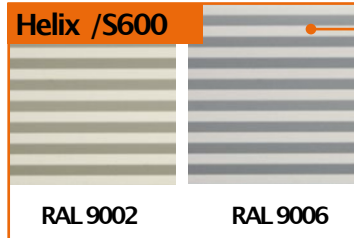

Helix /S600

### 2 colours

Do you have special requirements when it comes to the colour? Alpha can offer you a whole rainbow of colours.



Helix /S600

### Safety

The Helix as the S600 can be equipped with pre-running safety-edge or a light-grid. The light-grid is consisting of a receiver and transmitter, mounted into the track system, and therefore no wiring is required on the door leaf. This improves the operational reliability of this superfast door.

Specifications	Helix	S600
Max. Door leaf-surface	25 m <sup>2</sup> (350kg)	25 m <sup>2</sup> (350kg)
Max. Width	5000 mm	5000 mm
Max. height	5000 mm	5000 mm
Section height	366 -610 mm	366 -610 mm
Opening speed	1.1 m/s	1.1 m/s
Closing speed	0.5 m/s	0.5 m/s
Section-thickness	40 mm	40 mm
Section-Joint	Finger-protection	Finger-protection
ALU-sections option	ja	ja
U Value at 5.000 x 5.000 mm	1.77 W/m <sup>2</sup> K (complete ISO)	1.77 W/m <sup>2</sup> K (complete ISO)

### FEATURES AND BENEFITS

- Low maintenance (200,000cycles) Springless system.
- Pre-running safety-edge or light-grid (no wiring on the door leaf).
- Class 3 Wind load.
- High insulation value.
- Quick and simple installation because of pre-assembled track- and drive-system.
- High opening speed.



Helix

### Torque-tube

The Helix Spiral Door and the S600 are equipped with a direct drive aluminium Torque-tube and is without spring assistance.

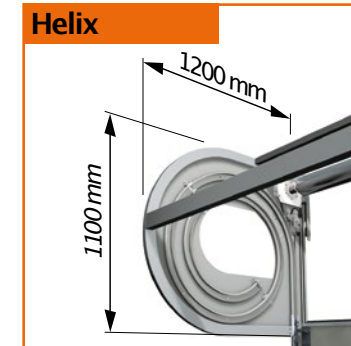

Helix

### Installation space

The Helix Spiral Door coils itself up against the interior facade of the building and the build in space is 1100 mm x 1200 mm at the head, 350 mm on the drive side and 120 mm on the non drive side.



Helix /S600

### Compact Side-hinges

For extra safety the panel connecting hinges are almost flat and ensure a perfect seal with the vertical side seals



Helix /S600

### Drive-concept

The uninterrupted chain-/ steel-cable system ensures precise and controlled door-movement even at high speed.

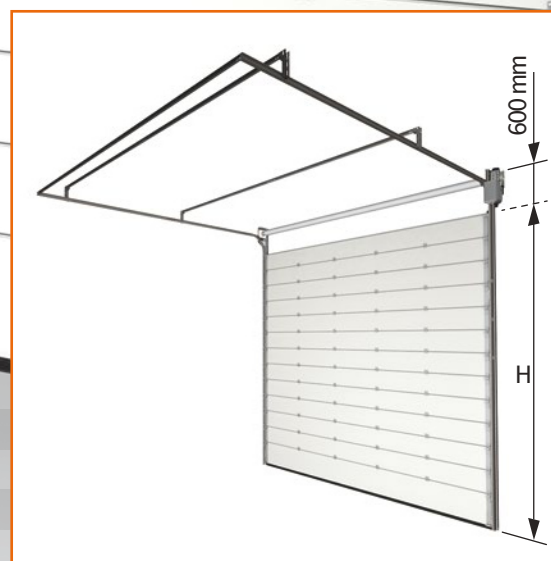

### Configuration doorleaf

The doorleaf for Helix and S600 are configured as mentioned in the overview below. The bottom section of the ALU doorleaf will always be an ISO section.

Helix /S600	ALU		ISO	
	Min	Max	Min	Max
Bottom section	-	-	366 mm	610 mm
Intermediate section	250 mm	366 mm	366 mm	366 mm
Top section	275 mm	366 mm	250 mm	366 mm